

Date _____
Customer _____
Project _____
Type _____

Flat moon suspension kit 4m / 5x0.75 triangle (3 cables) black struc

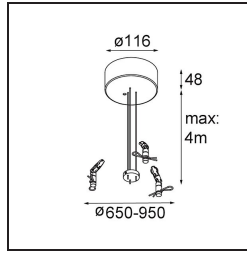
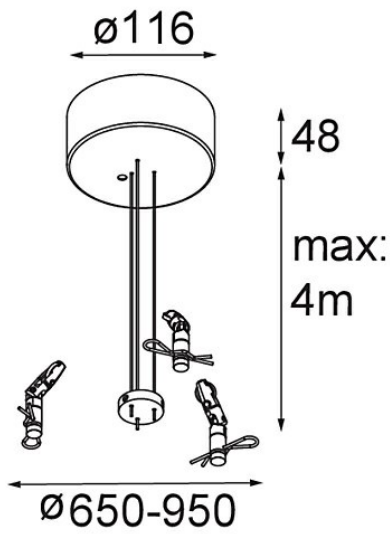

Specifications

Material	11066132
Lamp Included	No
Number of Light Sources	0
Input Voltage	230V
Electrical Class	I
IP Rating	20
Glow wire rating (°C)	960
Indoor/Outdoor	Indoor
Application	Ceiling
Mounting	Suspended
Adjustability	Not Applicable
Primary Colour & Primary Finish	Black, Structure
Gross weight (g)	1375.0