

Date \_\_\_\_\_  
Customer \_\_\_\_\_  
Project \_\_\_\_\_  
Type \_\_\_\_\_

*Flat moon suspension kit 4m / 9x0.75 triangle (3 cables) black struc*

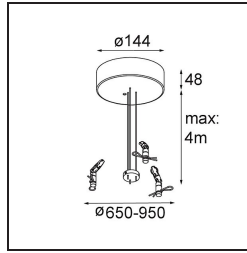
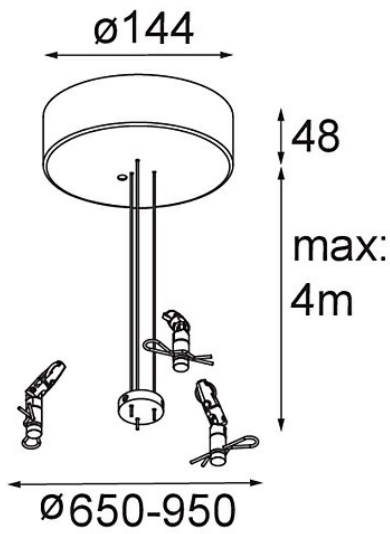

**Specifications**

Material	11066232
Lamp Included	No
Number of Light Sources	0
Input Voltage	230V
Electrical Class	I
IP Rating	20
Glow wire rating (°C)	960
Indoor/Outdoor	Indoor
Application	Ceiling
Mounting	Suspended
Adjustability	Not Applicable
Primary Colour & Primary Finish	Black, Structure
Gross weight (g)	1660.0